

Zhengzhou Sinodu Machinery Technology Co,Ltd.

Trusted name company & Comprehensive supplier in steel making

(REFRACTORIES UNIT)

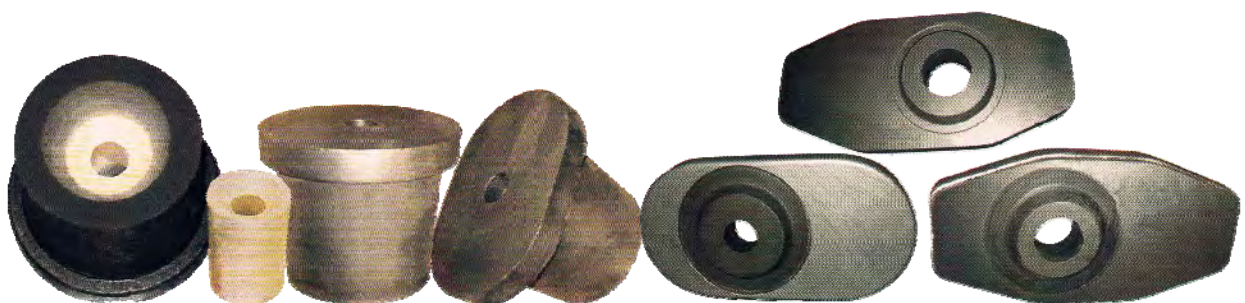



Brief

Zhengzhou Sinodu Machinery Technology Co Ltd is a Chinese company specialized in the field of various refractories for steel industry, machinery and spare parts for continuous casting of steel and rolling mill. ZSMT has registered office in Zhengzhou and producing workshops at three cities. A commercial network of agencies covers the Southeast Asia, Middle East, Europe and America market.

ZSMT `s corporate goal is to develop and manufacture products that meet customer demands, find solutions for their specific applications, and provide services as a long-term partner. ZSMT `s strategy for accomplishing this goal is based on a highly skilled and experienced workforce. ZSMT `s mission is to set up Chinese products' reputation and Chinese enterprise's fame to the world. ZSMT has the ability to invent and develop new materials and innovative production processes via ongoing advancement and training of its employees and the continual improvement of its engineering capabilities.

This catalogues is the unit of refractories, include ladle slide gate system, porous plugs, ladle brick linings, castables, metering nozzles, tundish linings and steady flow system, it will show you more details and lead you into fascinating refractory world.



Contents

Ladle Refractories

● Slide Gate Refractories.....	4
● Porous Plugs.....	7
● Mortar.....	8
● Bricks (MgO-C/Al ₂ O ₃ -MgO-C).....	9
● Castables.....	11
● Stuffing Sand.....	12

Tundish Refractories

● Steel Flow Control Refractories.....	14
● Dry Vibratable Mix and Castables.....	17
● Precast Refractory.....	18

Ladle Refractories

For the steel ladle ZSMT offers various customized solutions: from premium alumina to burnt magnesite, carbon-bonded magnesite, alumina-magnesia-carbon to spinel – in all standard shapes (special solutions and special shapes upon request) – as well as bricked or monolithic lining concepts or a combination of both. The corresponding lids are also available. Individual service packages round off the offer spectrum.

ZSMT offers optimal solutions for slide gate systems. Long-term expertise and close cooperation with our customers are the foundation of our quality, service and performance edge. Modern production equipment and a high automation degree ensure sustained premium quality and precision of offered products.

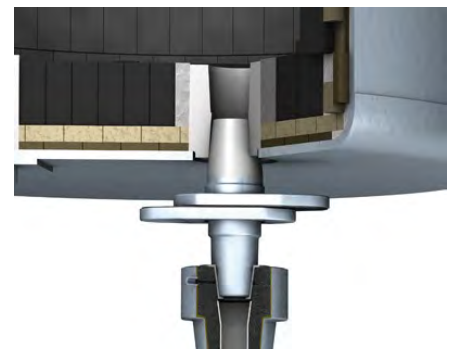
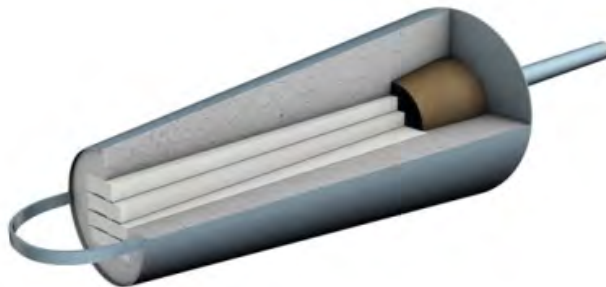
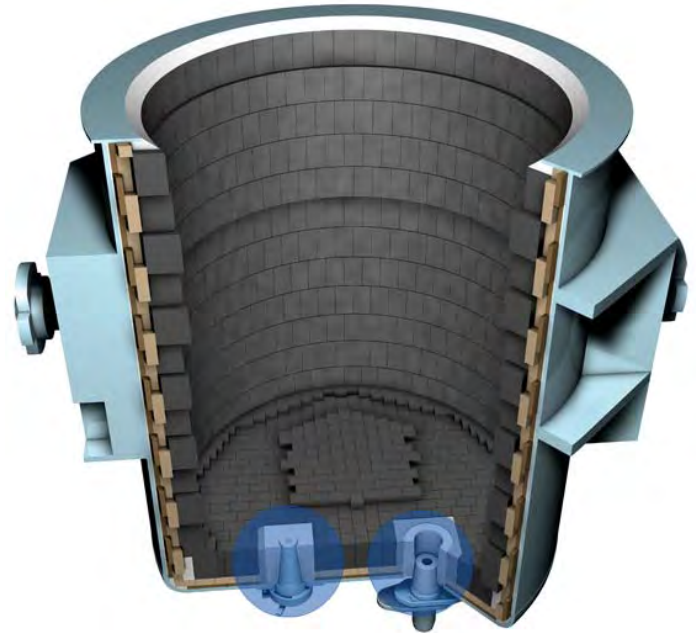

CIUC manufacturing range for Ladle Refractories

- *Steel flow control refractories (slide gate)*
 - high performance burnt slide plate
 - ladle/collector nozzle
 - pre-assembled slide plates and collector nozzles
- *Porous plugs*
- *High performance mortar*
- *Bricks (MgO-C & Al₂O₃-MgO-C Bricks)*
- *Refractory castables*
- *Stuffing sand*



High Performance Burnt Slide Plate

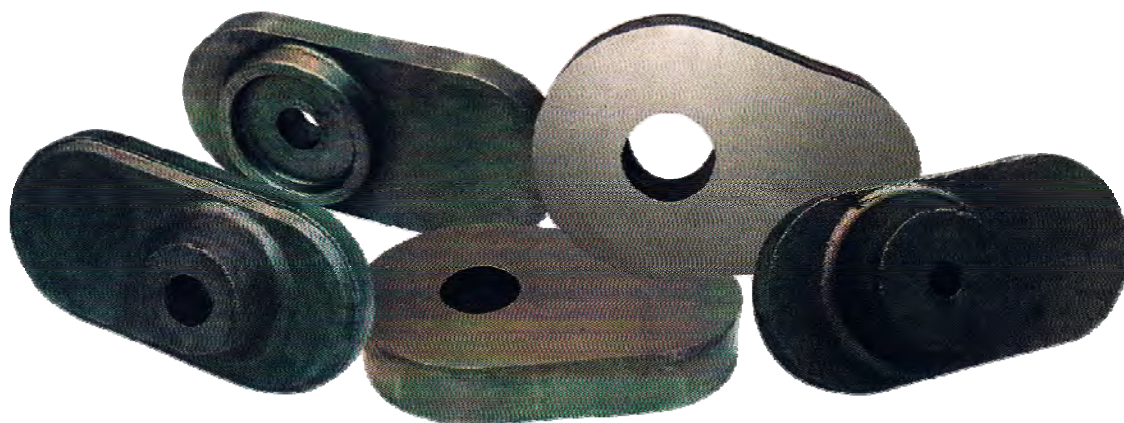

Brand	Al ₂ O ₃ (%) ≥	C (%) ≥	ZrO ₂ (%) ≥	Bulk density (g/cm ³) ≥	Apparent porosity		Compressive strength (MPa) ≥
					Pitch dipping	Calcination	
CSG-AC75	75	3	-	-	10	13	80
CSG-AZC70	70	3	5	2.9	8	13	100
CSG-AC70	70	3	-	-	8	-	80
CSG-AC90	90	1	-	3.0	-	-	160
CSG-MC80	MgO ≥ 80	5	-	2.9	8	12	75

High performance burnt slide plate is made of corundum and zirconia, and it is sintered under high temperature. The application in large size ladles, refining ladles and various kinds of alloy-steel ladles shows that it has strong oxidation resistance, good corrosion resistance and excellent properties at high temperature.



Ladle/Collector Nozzle



Brand	Al ₂ O ₃ (%) ≥	C (%) ≥	MgO (%) ≥	Apparent porosity (%) ≤	
				Pitch dipping	No pitch dipping
CN-AC65	65	5	-	10	14
CN-AC70	70	3	-	10	14
CN-AC85	85	3	-	10	14
CN-AMC40	40	5	5	10	18
CN-AMC45	8	5	45	10	18
CN-A65	65	-	-	10	19
CN-AZC80	80	ZrO ₂ ≥ 3	3	9	3.1

Ladle nozzle is made of superior bauxite or corundum and flake graphite as raw materials. CIUC focuses on optimizing base material, producing through high pressure forming process, gives this product advantages of high corrosion resistance, long service life and good integrity, achieved the international advanced level.

Collector nozzle includes three types: alumina-zirconia-carbon based, alumina-magnesia-carbon based and alumina-carbon based, characterized by low porosity, high strength, good thermal shock resistance, high corrosion resistance and long service life, which can meet the requirements of different kinds of steel casting processes.

Pre-assembled Slide Plates and Collector Nozzles

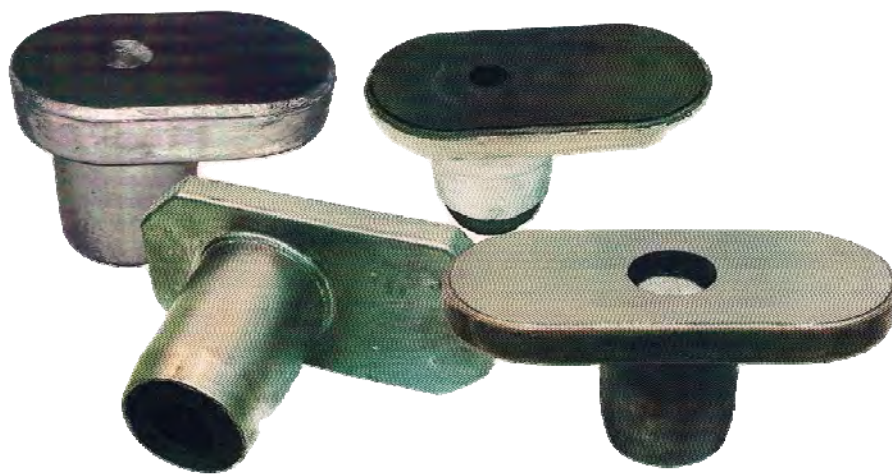

Brand	Al ₂ O ₃ (%) ≥	MgO (%) ≥	C (%) ≥	Apparent porosity (%) ≤	Bulk density (g/cm ³) ≥	Compressive strength (MPa) ≥
CCN-AM80	80	12	-	15	3.0	80
CCN-A90	90	-	-	15	3.1	100
CCN-M90	-	90	-	16	2.9	100
CSG-A94	94	-	-	18	3.0	85
CSG-AMC55	55	8	8	10	2.9	-
CSG-AZC80	80	ZrO ₂ ≥ 3	3	9	3.1	-

Usually, slide plate and collector nozzle are pre-assembled together and combined by steel shell and binder. Collector nozzle is shaped by mold press, raw materials are alumina-carbon or alumina-zirconia-carbon based.

Monolithic pouring technology has been developed and put into producing. This process does not need binder between slide plate and collector nozzle, good integral structure improves security greatly. Monolithic pouring collector nozzle has more material options, such as magnesia, corundum, alumina-magnesia-carbon based etc., which can meet different kinds of steel production requirements and enables continuous service for several times.

Porous Plugs

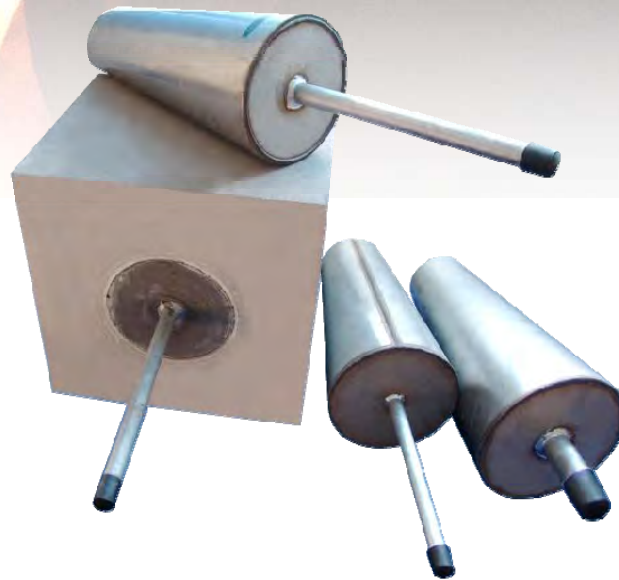

Item	Index		
	CPP-AM92	CPP-AM95	
Chemical ingredients (%) \geq	Al ₂ O ₃ +MgO	92	95
	Cr ₂ O ₃ (C)	4	4
Apparent porosity (%) \leq		15	13
Bulk density (g/cm ³) \geq		3.10	3.15
Cold compressive strength (MPa) \geq		150	150

The bottom blow porous plug is the weak link of ladle refractory and also the primary factor that affects the ladle's service life. For secondary refining like the LF process, stirring the molten steel via porous plugs is indispensable and the reliability of the stirring greatly influences steel quality.

The requirements of porous plugs are:

1. Resistance against molten steel penetration
2. Corrosion resistance
3. Thermal spalling resistance.

Primarily focusing on the reliability of the stirring effect, CIUC has been designing and developing high-quality porous plugs, and offering them in compliance with clients' operational conditions, e.g., the requested gas flow rate.

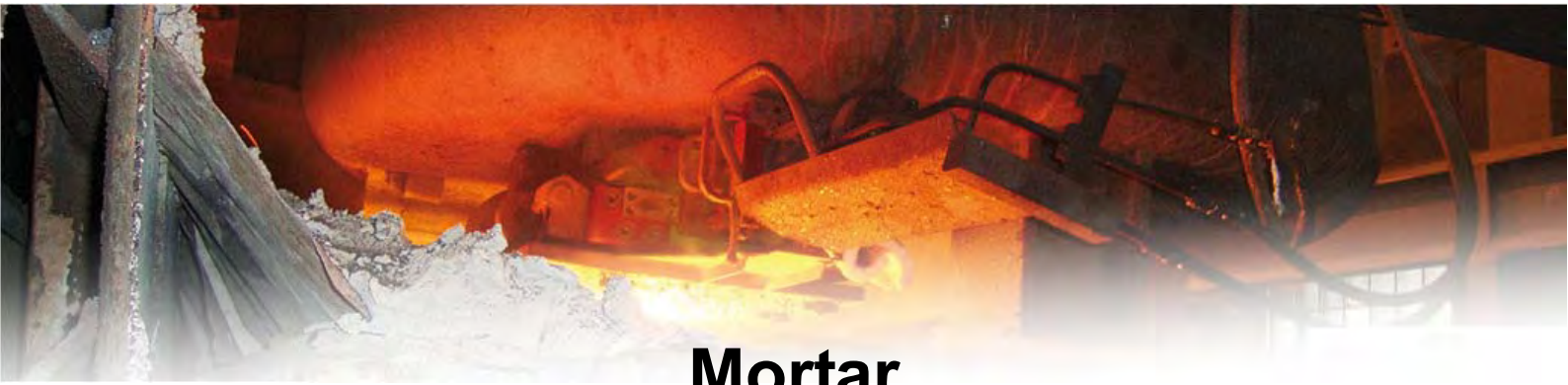

Mortar

Brand		CM-AC70	CM-AC80	CM-ACr90	CM-M90	CM-AM75
Granularity (mm)	>0.5	<1	<1	<1	<1	<1
	≤0.076	≥50	≥50	≥50	≥50	≥50
Modulus of rupture (MPa)	110°C	≥15	≥15	≥15	≥15	≥15
	800°C	20--25	20--25	20--25	20--25	20--25
	1000°C	≥50	≥50	≥50	≥50	≥50
	1350°C	≥60	≥60	≥60	≥60	≥60
Chemical ingredients (%)	Al ₂ O ₃ +Cr ₂ O ₃	≥70	≥80	≥90	-	≥75
	MgO	-	-	-	≥95	≥15
	C	3	3	-	-	-

Mortar is divided into chrome-corundum based, alumina-carbon based, high alumina based, magnesia based and alumina-magnesia based, this product is used as binder between upper nozzle and well block, between slide plate and lower nozzle, installing porous plugs and ladle bricks.

The features as follows:

1. Stable quality, easy to transport.
2. Easy to use by adding water and mixing them up, then you can use it immediately, no need to ageing the mixture.
3. Whether it's in high, middle or low temperature condition, it has excellent adhesion strength, high corrosion resistance, good integrity and high structural strength.

Tips: Choosing Sinodu's mortar to use cooperatively with Sinodu's slide gate will increase the slide gate service life more than 20%.

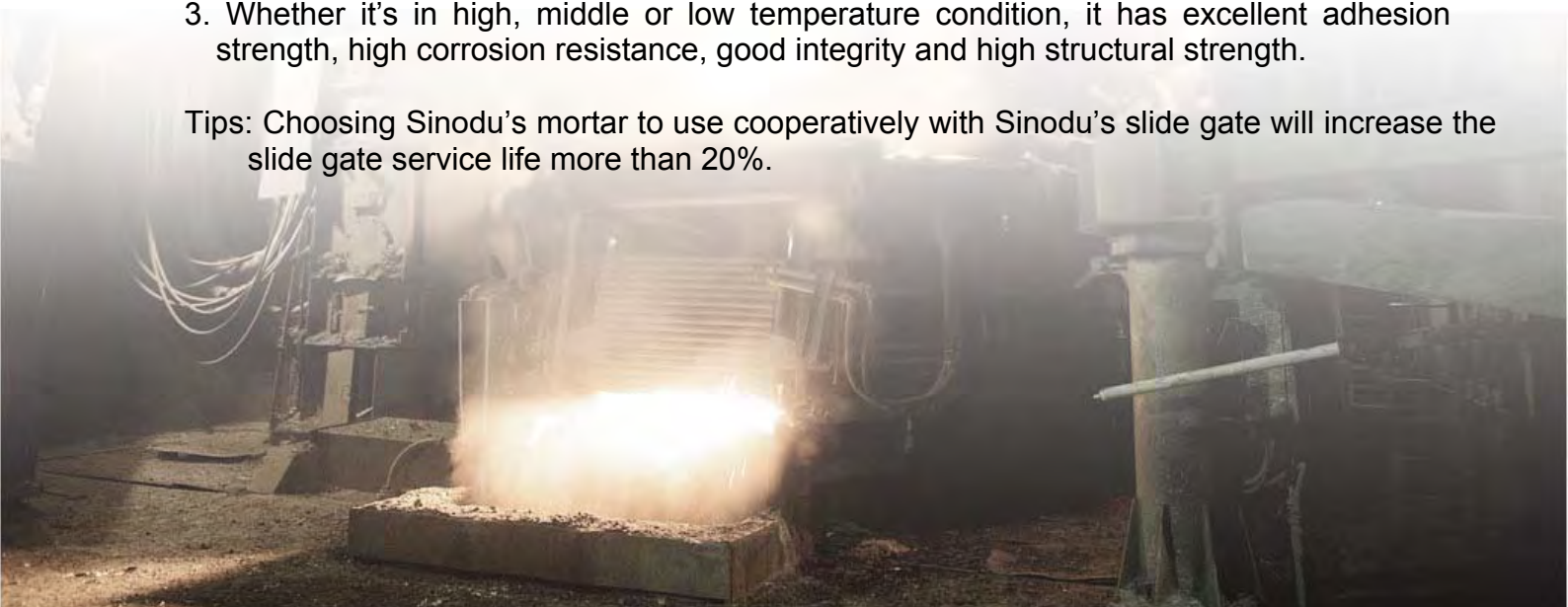

MgO-C Bricks

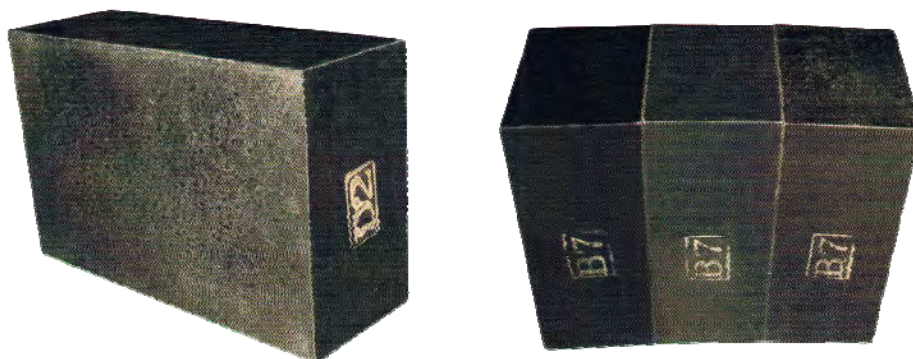

Item		Index					
		CMC -10A	CMC -14A	CMC -14C	CMC -18A	CMC -18B	CMC -8C
Chemical ingredients (%) \geq	MgO	80	76	74	72	70	85
	C	10	14	14	18	18	(\leq)8
Apparent porosity (%) \leq		4	4	6	3	4	5
Bulk density (g/cm ³) \geq		2.90	2.90	2.77	2.90	2.82	3.0
Cold compressive strength (MPa)		40	40	25	40	35	50
Modulus of Rupture (1400°Cx0.5h) (MPa) \geq		6	12	5	10	7	12

Magnesia carbon bricks are made of the high purity, high density large crystalline magnesite, high purity graphite and resin. This product is shaped by high pressure forming process; it is widely used in electric furnace lining, converter lining and ladle furnace lining. The customers can choose different specifications of magnesia carbon bricks according to different requirements. The product is characterized by high strength, high slag resistance, good thermal shock resistance and high refractoriness.

Low carbon MgO-C bricks are made of high purity fused magnesia and flake graphite, add in advanced binder and specific anti-oxidation additives, shaped by high pressure forming process. Benefit of superior materials and production technology, realized the low carbon content and low pollution to molten steel, it's very suitable for the low carbon refining furnaces like LF-VD.

Al₂O₃-MgO-C Bricks

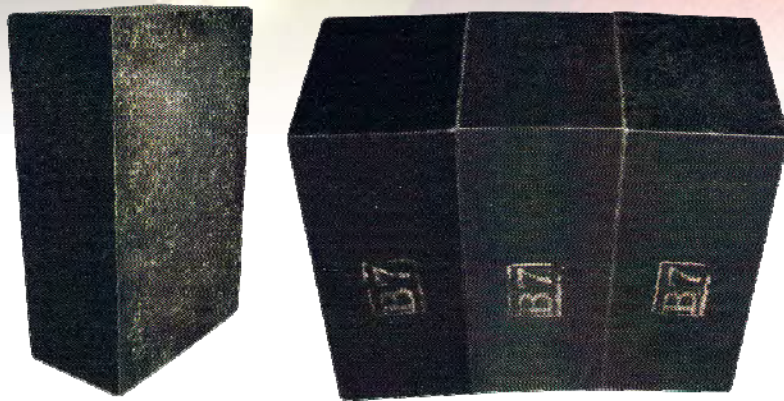

Item	Index			
	CAMC76	CAMC74	CAMC72	
Chemical ingredients (%) ≥	Al ₂ O ₃	76	74	72
	MgO	14	12	10
	C	8	8	7
Apparent porosity (%) ≤		8	9	10
Bulk density (g/cm ³) ≥		2.90	2.85	2.80
Cold compressive strength (MPa) ≥		55	45	40
Refractoriness under load (0.2Mpa,0.6%) (°C) ≥		1670	1630	1600

Alumina-magnesia-carbon bricks are made of superior bauxite or corundum. Sinodu focuses on optimizing base material, producing through high pressure forming process, gives this product advantages of high corrosion resistance, long service life and good integrity, suitable for the ladle bottom lining and wall lining.

Castables

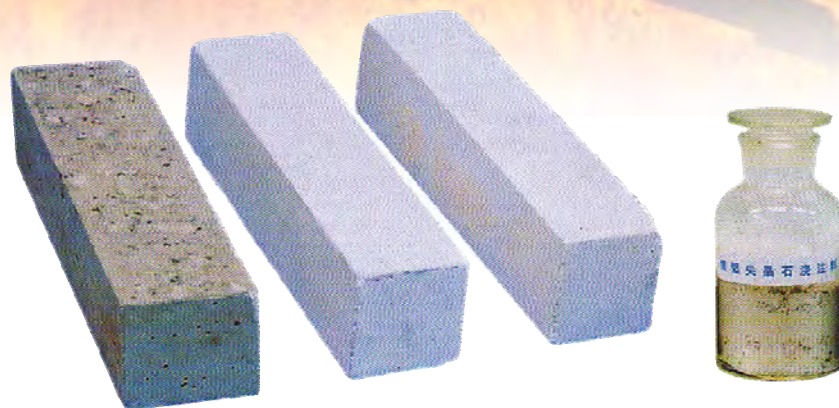

Item		CC-AM78	CC-AM90	CC-AS1	CC-AS2	CC-AS3
Al ₂ O ₃ (%) ≥		78	90	78	90	95
MgO (%) ≥		12	6	-	-	-
SiO ₂ (%)		-	-	10	2	0.3
Bulk density (g/cm ³)	110°Cx24hr	2.8	2.8	3	3.1	3.0
	1000°Cx3hr	2.85	2.85	3	3.05	3.0
	1550°Cx3hr	2.85	2.85	3	3	3.0
Compressive strength (MPa)	110°Cx24hr	60	60	80	100	40
	1000°Cx3hr	65	65	90	120	90
	1550°Cx3hr	70	100	120	120	120
Modulus of rupture (MPa)	110°Cx24hr	9.0	9	12	12	4.5
	1000°Cx3hr	7.5	8	18	20	18
	1550°Cx3hr	10	-	-	-	20
Usage		10-50 Mt Ladle	50-300 Mt ladle	For special high temperature equipments		

Al₂O₃-MgO series castables are mainly divided into three classes: high, middle and low class. High class castable is made of electric fused white corundum, sintered tabular corundum and electric melted magnesia etc, it is mainly used in converter, electric furnace ladle lining and refining ladle, which has excellent corrosion resistance to slag and impermeability.

Al₂O₃-SiO₂ series castables are characterized by high strength, high service temperature, excellent abrasion resistance and corrosion resistance. It includes dense high strength refractory castable, low cement refractory castable, cement-free refractory castable and corundum refractory castable. They can be used in pouring, ramming or spray coating.



Stuffing Sand



Brand	Cr ₂ O ₃ (%) ≥	SiO ₂ (%) ≥	C (%) ≤	Fe ₂ O ₃ (%) ≤	H ₂ O (%) ≤	Granularity (mm)
CSS-01	30	≤35	1	10	1	1-3
CSS-02	-	94	1	1	1	1-3
CSS-03	18	≤65	1	7	1	1-3

The stuffing sand is mainly used in the ladle sliding gate for automatically casting. According to the steel kinds and casting rate, we've developed two products series: chromite-based and silicon-based stuffing sand. Chromite-based stuffing sand mainly used in refining ladle, which automatic casting ratio reaches to 95%; silicon-based stuffing sand is developed with optimal formula and new production process, which automatic casting ratio can reach up to 98%.

Tundish Refractories

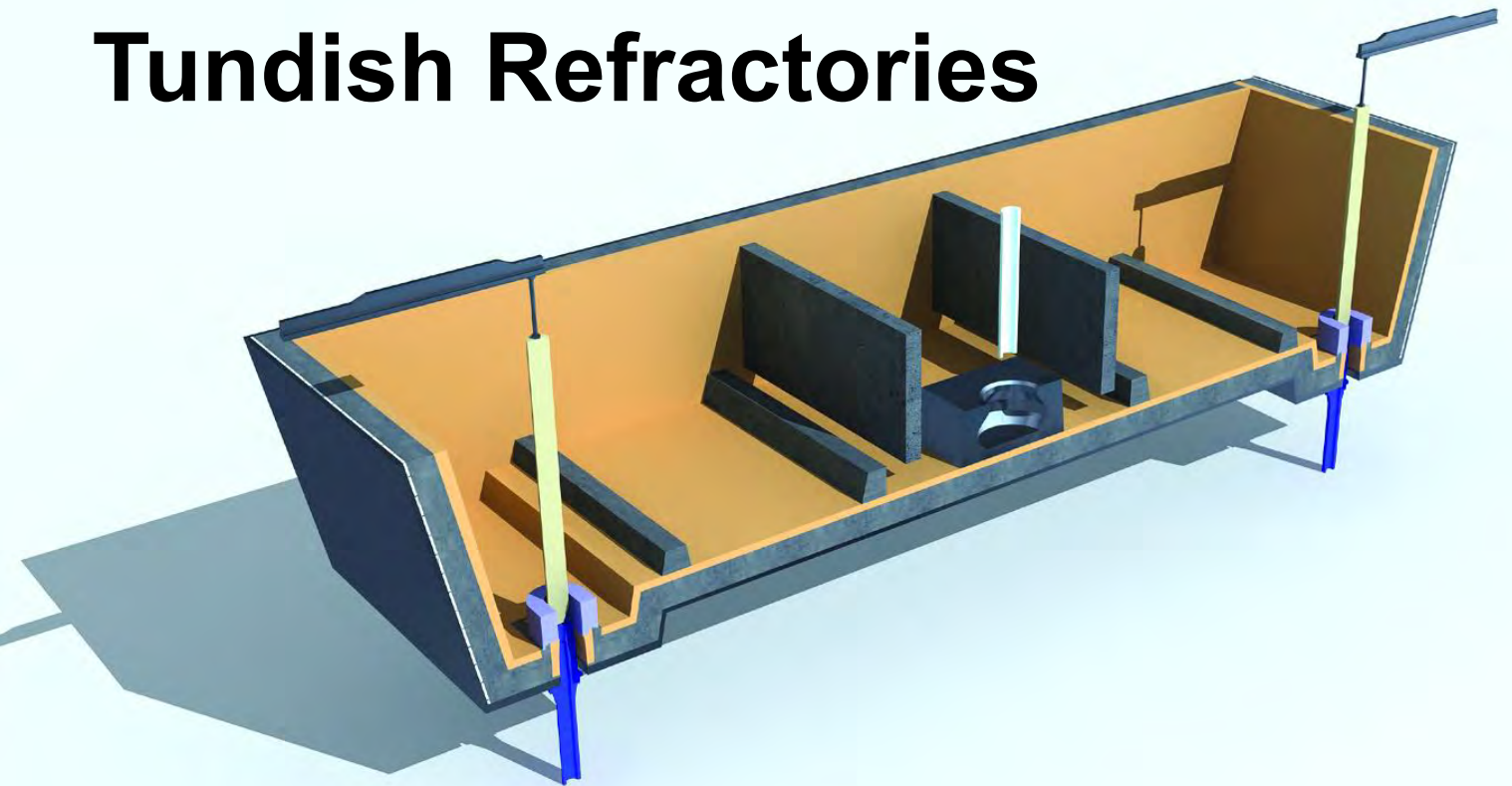

The tundish nozzle is seen as the most critical component of the tundish since it cannot be replaced during casting. Sinodu is a leader in the development of tundish refractories, capable of reducing clogging. Beyond our available products, several new designs and materials are in the development stage, creating the future generation of advanced clogging reduction nozzles.

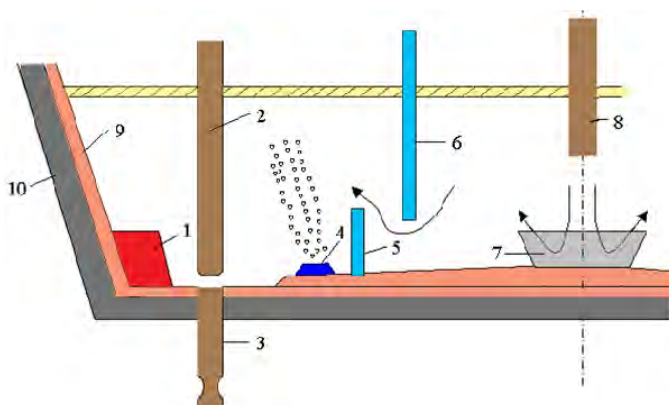

- 1. Whirl Eliminator; 2. Stopper Rod; 3. Submerged Nozzle;
- 4. Porous Bar; 5. Dam; 6. Baffle; 7. Impact Pad;
- 8. Ladle Shroud; 9. Working Lining; 10. Permanent Lining

SINODU manufacturing range for Tundish Refractories

- *Steel flow control refractories (metering nozzle)*
 - metering nozzle/slide block
 - quick change submerged nozzle
 - and matched slide plate for blowing argon gas
 - well block
- *Dry vibratable mix for working lining and castables for permanent lining*
- *Tundish steady flow system*

Metering Nozzle/Slide Block



Item		Index			
		CSN-AC75	CSN-AC80	CTN-Z94	CTN-Z92
Chemical ingredients (%) \geq	Al ₂ O ₃	75	80	-	-
	ZrO ₂	-	-	94	92
	C	4	4	-	-
Apparent porosity (%) \leq		8	7	14	15
Bulk density (g/cm ³) \geq		2.90	2.95	5.2	5.0
Cold Compressive strength (MPa) \geq		60	60	80	80
Modulus of rupture (1400°C x0.5h) (MPa) \geq		6	7	30	25

Tundish slide block is one of the matching products in metering nozzle quick changing device, which is our patented product. It can be used in continuous casting process for producing any kinds of square billet. Our third generation products can be used together with the stopper rod to pour all kinds of alloy steel or special steel.

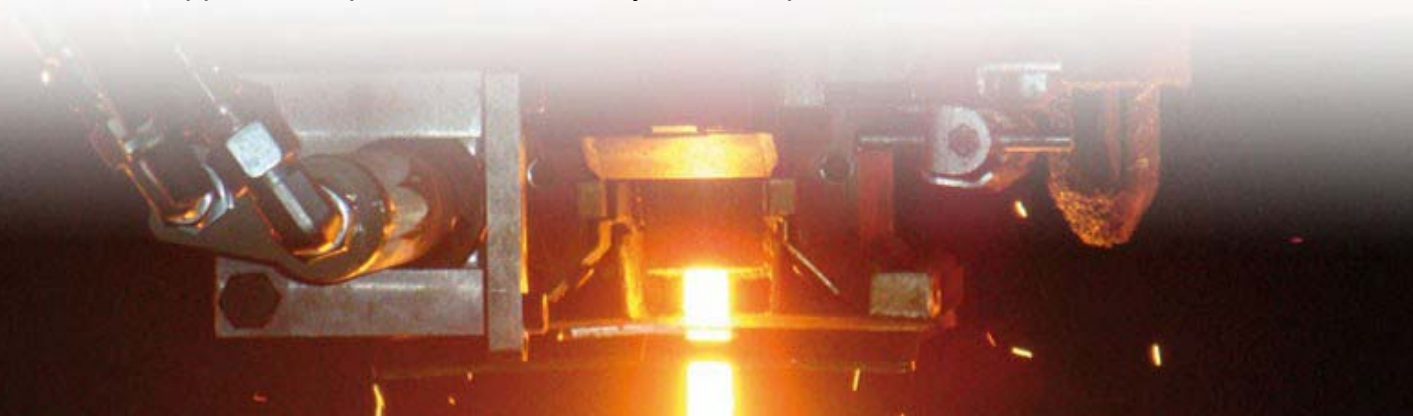

Quick Change Submerged Nozzle and Matched Slide Plate for Blowing Argon Gas



Item	Submerged nozzle		Slide plate for blowing argon gas	
	CSN-AC	CSN-ZC	CSP-AC	CSP-AZC
Al ₂ O ₃ (%) ≥	45	-	85	80
C+SiC (%) ≥	26	15	5	5
ZrO ₂ (%) ≥	-	70	-	5
Apparent porosity (%) ≤	18	20	8	7
Bulk density (g/cm ³) ≥	2.5	3.20	3.0	3.1
Cold Compressive strength (MPa) ≥	20	20	80	80
Modulus of rupture (MPa) ≥	7.0	7.0	7.0	10.0

Quick change submerged nozzle is used in shielded casting practice between tundish and mould, cooperating with stopper to control steel pouring speed, shield strand and adjust its casting direction. This product has excellent thermal shock stability, corrosion resistance and high mechanical strength.

SINODU offers three types of matched slide plates for blowing argon gas: zirconia core, alumina-zirconia-carbon and zirconia-carbon, meet the requirements of different kinds of steel production and different service life.

Well Block

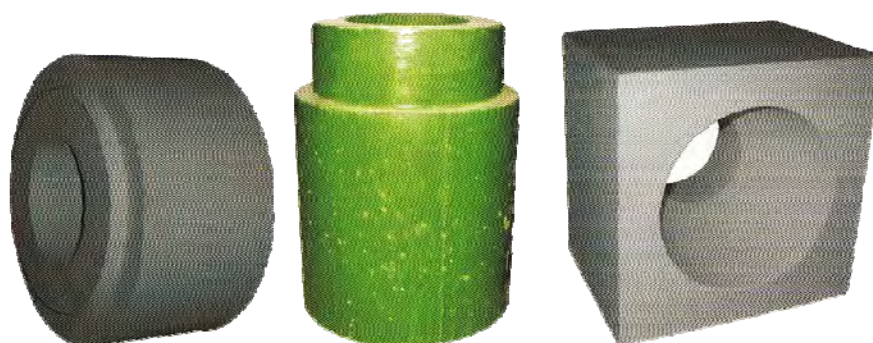

Item		Index (CWB)						
		A75	A80	AC75	AZC75	A90	A95	AC85
Chemical ingredients (%) \geq	Al ₂ O ₃	75	80	75	75	90	93	85
	ZrO ₂	-	-	-	4	-	-	-
	C	-	-	3	3	-	-	3
Apparent porosity (%) \leq		15	14	8	7	12	12	7
Bulk density (g/cm ³) \geq		2.90	2.95	2.95	3.05	3.00	3.10	3.00
Compressive strength (MPa) \geq		60	60	50	50	80	80	50
Modulus of rupture 1400°C x0.5h (MPa) \geq		6	7	8	12	12	15	10

Well block mainly apply to nozzle quick changer, common metering nozzle, stopper for slab casting and slide gate nozzle. This product can be made of high alumina, corundum, alumina-carbon and alumina-zirconia-carbon, meets the requirements of different kinds of steel production and different service life.

Dry Vibratable Mix for Working Lining and Castables for Permanent Lining



Item		CVM-M80	CVM-M90	CC-A80	CC-A65
Al ₂ O ₃ (%) ≥		-	-	80	65
MgO (%) ≥		80	90	-	-
CaO (%)		12	2	1.2	1.5
Bulk density (g/cm ³)	110°C x24hr	2.65	2.70	2.80	2.75
	1000°C x3hr	2.55	2.65	2.80	2.75
	1500°C x3hr	2.85	3.0	2.75	2.70
Compressive strength (MPa)	110°C x24hr	6	4	60	50
	1000°C x3hr	8	9	80	60
	1500°C x3hr	12	16	100	80

SINODU has complete facilities and thorough experience for offering tundish lining.

We offer two kinds of dry vibrating mix used for working lining of tundish: magnesia based and magnesia-calcium based. The materials have the advantages of long service life, easily dissolution and no pollution to molten steel.

The castables for permanent lining of tundish are mainly made of high bauxite and andalusite, their excellent physical and chemical properties and resistance to thermal shocks provide a safe and long lasting lining for tundish.

Precast Refractory for Tundish

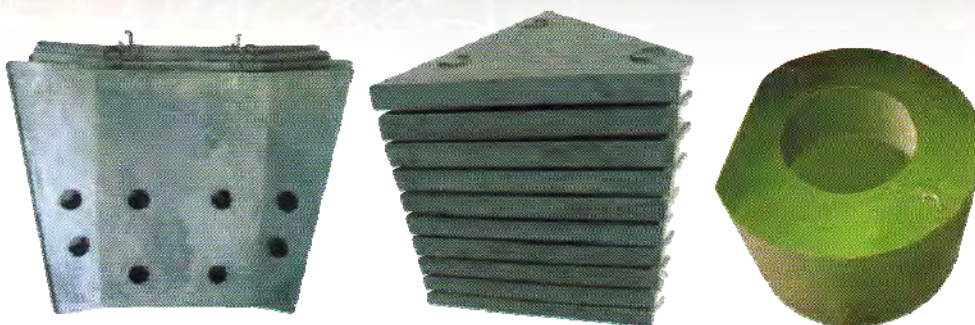

Item	Index				
	CPC-AM75	CPC-M85	CPC-M90	CPC-M95	CPC-CrM95
Al ₂ O ₃ (%) ≥	15	-	-	-	-
Cr ₂ O ₃ (%) ≥	-	-	-	-	5
MgO (%) ≥	75	85	90	95	90
SiO ₂ (%) ≥	2	-	3	3	-
Apparent porosity (%) ≤	15	14	8	7	12
Bulk density (g/cm ³) ≥	2.90	2.95	2.95	3.05	3.00
Compressive strength (MPa) ≥	60	60	50	50	80
Modulus of rupture 1400°C x0.5h (MPa) ≥	6	7	8	12	12
Usage	Skimmer / dam				Flow stopper

The function of tundish steady flow system is to disperse the impact force of molten steel flowing into the tundish. First the hot molten steel stream comes down from ladle shroud flows directly into the impact pad, then stopped spread by the dams, weir plates and baffles, the molten steel can outflow steadily with high quality. This system improves the service life of tundish and reduces the cost of casting process. We can provide customized products by analyzing the simulation data and FEA (Finite Element Analysis) data, all products are manufactured with superior physical and chemical properties for safe casting and clean steel production.

Contacts

Mr. MUHAMMAD KASHIF
Room 2211, Tower A, Asia Pacific Times
Plaza, Economic Development Zone,
Zhengzhou - China.
Phone No: +86 13949 102044
Website: www.sinodu.com